

Specifications

And

Instructions For Replacement of Windows

PARKFAIRFAX CONDOMINIUM UNIT OWNERS ASSOCIATION



Revised March 18, 2026

INSTRUCTIONS FOR APPROVAL OF REPLACEMENT WINDOWS

The installation of replacement windows must conform to these window specifications. Administrative approval is required prior to the installation.

1. Obtain the following documents from the Association Office:
 - Window Specifications
 - Administrative Application for Routine Change
 - Indemnification Agreement and Covenant
 - A diagram of the unit

2. Fill out the Administrative Application for Routine Change and attach the following:
 - The diagram of the unit indicating which of the Replacement Window Packages (Package 1, Package 2 or Package 3) will be installed in the unit and the corresponding W.O. Window #x and code (DHxx, Cxx, SLxx, Fxx or AWNxx) in each opening. Include the name of the unit type on the diagram (e.g. Washington, Lincoln, Madison, Adams, etc.). (An explanation of each window type is shown on the attached Window Style Definitions.)

 - Indemnification Agreement and Covenant signed by ALL unit owners and notarized.

 - A copy of the contract reflecting the measurements of each window opening and a copy of the contractor's license and certificate of insurance.

 - A copy of the manufacturer's and installer's (if manufacturer isn't installing the windows) warranty.

3. Return all of the above documents to the Association Office.

4. The General Manager or Covenants Director will review your application, and if all of the above documents are in order you will be notified of the disposition of your application.

5. The Covenants Director will obtain the Association President's or the Association Manager's notarized signature on the Indemnification Agreement and file it in your unit owner's file.

6. Please call the Covenants Director at 703-998-6315 if you have any questions and/or to ensure all your documents have been properly filled out.

PARKFAIRFAX CONDOMINIUM UNIT OWNERS ASSOCIATION SPECIFICATIONS FOR REPLACING WINDOWS

Administrative approval is required for replacement windows prior to the installation. All of the windows on one façade/side of the unit must be replaced at the same time. All windows in a unit must be from the same Replacement Window Package – Package 1, Package 2 or Package 3.

Replacement of individual windows that have been damaged is allowed as long as the replacement window is of the same material and window type with the same grille (grille/muntin/mullion (the vertical or horizontal bars between adjacent panes of glass in a window)) pattern as the window being replaced. In the event of damage to one or more, but less than all, of the original steel windows, the unit owner shall submit an Administrative Application for Routine Change for Approval of Replacement Windows for the replacement of the windows damaged beyond repair as described herein.

If all of the original steel windows are being replaced, the unit owner shall submit an Administrative Application for Routine Change for Approval of Replacement Windows as described herein.

Replacement of glazing that has become fogged or broken is allowed as long as the grille pattern is the same as the window that is being replaced. No application is required when replacing the glazing with the same grille pattern.

I. RESPONSIBILITY

The Unit Owner is responsible for the proper installation of new windows and any damage that might occur to the unit or common element due to improper installation. All improvements to a unit must meet local and state building codes.

The Association reserves the right to correct or replace, at the unit owner's expense, any new window which has been improperly installed or does not meet the approved specifications. This shall be done in accordance with approved procedures for redress or violation.

II. CONTRACTOR

Installation of replacement windows must be performed by a licensed and insured (general liability insurance and, as required by Virginia law, workers' compensation insurance) contractor.

III. WINDOW TYPE & SIZE

The replacement thermal pane windows must have exteriors made of a white, maintenance-free material such as fiberglass, aluminum or vinyl. New windows must be "custom sized" to fit within the masonry opening of the existing windows. The window opening may not be adjusted inward by any devices to allow the use of "standard size" windows. Removal of the

steel frame defining the window opening may only be done with written approval from the General Manager and will be decided on a case-by-case basis.

New windows must comply with the Virginia Uniform Statewide Building Code (USBC), which has established a minimum fenestration U-factor of 0.35 for windows. The USBC for this requirement is shown in the links below.

Code:

<https://www.dhcd.virginia.gov/virginia-uniform-statewide-building-code-usbc>

Map showing Virginia is in Climate Zone 4A:

https://codes.iccsafe.org/content/VRC2015/chapter-11-re-energy-efficiency#VRC2015_Pt04_Ch11_SecN1101.7

Table showing the minimum fenestration U-factor:

https://codes.iccsafe.org/content/VRC2015/chapter-11-re-energy-efficiency#VRC2015_Pt04_Ch11_SecN1102.1.2

Note: The above links are correct as of February 2026.

Replacement of the existing steel casement windows with substantially similar steel casement windows requires Parkfairfax Board of Directors approval. Replacement of windows using steel casement windows is allowed only if the original steel casement windows are being replaced.

Bay Windows

Note: The prior window specifications didn't provide specifications for the replacement of bay windows. All replacement of existing bay windows shall conform to this specification.

In certain units in Parkfairfax, bay windows are installed in the living/dining rooms. The window diagrams show the allowable window replacement configuration for the windows.

The two posts at the front corners of the bay windows shall not be removed at any time. If these two posts are found to be in need of repair during the replacement of the bay window or side door on the ground floor units with bay windows, Parkfairfax should be contacted immediately and the unit owner shall submit a maintenance request.

Ground floor units have a patio door installed on one face of the bay window. The specification for the replacement of the patio door is defined in the Back Door Specifications.

IV. WINDOW STYLE & GRILLE CONFIGURATION

Replacement windows must be installed according to the installation diagrams contained in this package. The architectural style of the windows shall be colonial with grilles as shown in the accompanying diagrams.

Clear translucent, patterned, frosted or opaque glass may be used for bathroom replacement windows only. No white or colored glass is allowed.

Replacement window units shall consist of either (1) individual glass panes set in the grille grid work (also known as “true divided lights or simulated divided lights”) or (2) non-removable (permanently affixed) gridwork placed between glass panes surrounded by window frame.

Grilles of any replacement window may not be removable. Grilles must be designed so that they are permanently attached either by the manufacturer or by the distributor in such a manner that any attempt to remove them would damage the window.

Unit Owners may choose to replace their windows with either single hung/double hung, casement, or sliding windows. These are shown on the accompanying Window Replacement Packages. **All windows must be chosen from the same Replacement Window Packages – Package 1 (single/double hung), Package 2 (casement), or Package 3 (sliding).**

For window openings 1, 3, 7 and 8 awning windows are allowed when the window is serving a bathroom or kitchen for Package 1, Package 2 and Package 3.

In addition, in certain rare circumstances, fixed non-operable windows are allowed.

Before the replacement of any existing windows, Unit Owners must: (1) decide whether they want their windows to be single/double hung, casement or sliding; (2) find the window opening number that matches each window in the unit to the corresponding existing opening dimensions shown in the first two columns – Rough Open WXH and Original 1941-1943 Windows; (3) choose Windows Package 1 (single/double hung), Package 2 (casement) or Package 3 (sliding); and (4) mark the W.O. Window #x and code (DHxx, Cxx, SLxx, Fxx or AWNxx) of each window next to each window opening on a diagram of their unit. Diagrams of units are available at the Parkfairfax Office or online at www.parkfairfax.org/resources/floor-plans. See Appendix A for additional information.

V. CAULKING

All exterior portions of the steel frame must be covered with white vinyl or aluminum flashing and caulked to prevent exposure of the frame to weather. It is recommended that an insulating material be placed between the flashing and the steel frame to reduce the chance of condensation forming on the exposed steel framing in the interior of the unit.

VI. CLEAN UP

Each Unit Owner or his/her contractor is responsible for the proper disposal of all debris generated by the replacements.

Old windows may **not** be disposed of in the maintenance yard.

Window Style Definitions

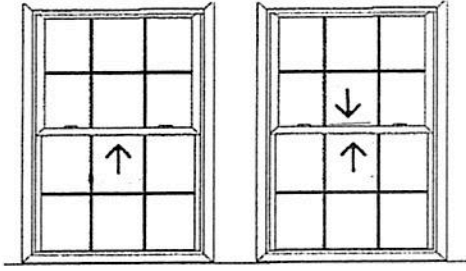

Single Hung: The top sash does not open; it is fixed. The window can only be opened by lifting the bottom sash up.

Double Hung: Both the top and bottom sashes are operable. The window opens from the bottom and, in addition, the top sash will slide down, so you can open top, both, or both.

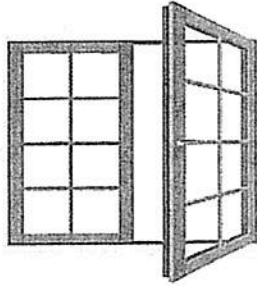

Casement: The sashes have hinges attached to the frame on one side allowing them to swing open in an outwardly direction.

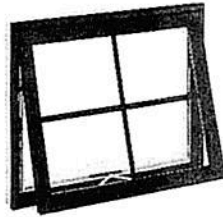

Awning: The sash has hinges at the top of the frame, and opens outward from the bottom.

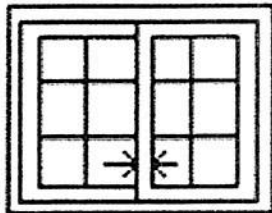

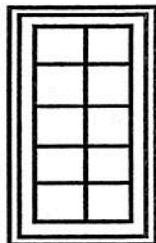

Slider: The sashes open by sliding horizontally along a top and bottom track in the window frame.



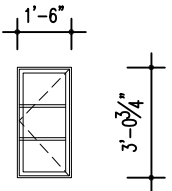
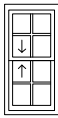
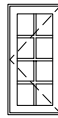
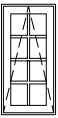
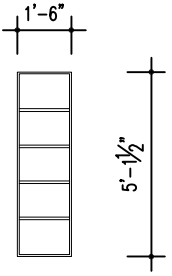
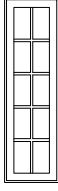
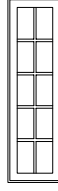
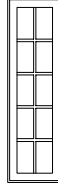
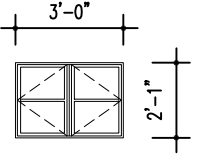
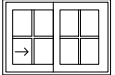
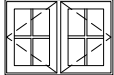

Fixed: A fixed window is set in the closed position in the frame. It is stationary and cannot open (non-operational).

| WINDOW CODE | |
|-------------------------------|--------------|
| DH = DOUBLE HUNG | AWN = AWNING |
| C = CASEMENT | |
| SL = SLIDING | |
| F = FIXED | |
| R = RETURN AT BAY WINDOW | |
| ROUGH OPENING = OPNG IN BRICK | |

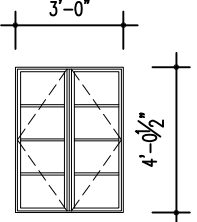
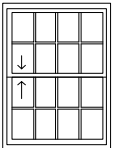
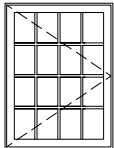
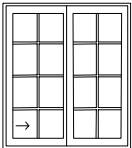
W.O. = WINDOW OPNG
NUMBER IN EACH
IN EACH WINDOW CODE
MEANS THE NUMBER OF
LITES OR SQUARES IN
EACH WINDOW

| ROUGH OPENING W X H | ORIGINAL 1941 - 1943 WINDOWS | REPLACEMENT WINDOW PACKAGES | | | | |
|--|---|---|---|---|---|------|
| | | PACKAGE 1 | PACKAGE 2 | PACKAGE 3 | AWNING OPTIONS | |
| Window Types | Custom Steel | Double Hung Single Hung | Casement | Sliding | Awning | |
| W.O. Window #1 1'-6" x 3'-0 3/4" Bathroom Window Fixed Not Allowed |  | DH8  | C8  | OR | OR  | AWN8 |
| W.O. Window #2 1'-6" x 5'-1 1/2" Sidelite Window at Patio Door See Door Spec |  | F10  | F10  | F10  | NOT APPLICABLE | |
| W.O. Window #3 3'-0" x 2'-1" Top of Stair or Bathroom Window |  | SL8  | C8  | OR | OR  | AWN8 |
| W.O. Window #4 3'-0" x 4'-0 1/2" Stair Window |  | DH16  | C16  | SL16  | NOT APPLICABLE | |

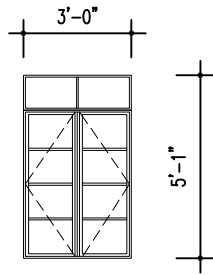
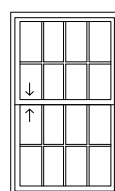
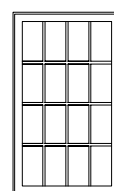
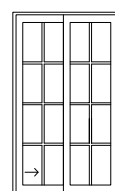
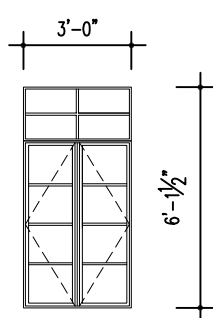
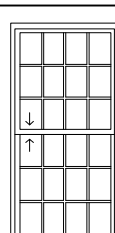
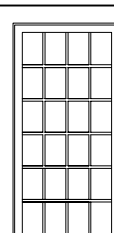
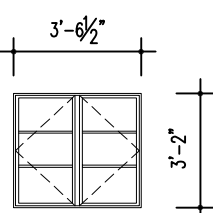
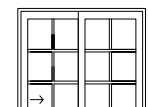
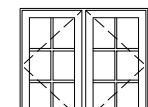
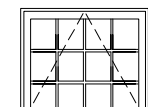
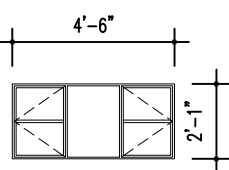
WINDOWS 1-4

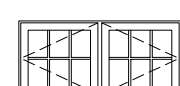
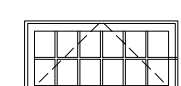
| ROUGH OPENING W X H | ORIGINAL 1941 – 1943 WINDOWS | REPLACEMENT WINDOW PACKAGES | | | | | |
|--|---|---|----------------------------------|--|----------------|---|-------------------|
| | | PACKAGE 1 | PACKAGE 2 | PACKAGE 3 | AWNING OPTIONS | | |
| Window Types | Steel Casement | Double Hung Single Hung | Casement | Sliding | | | |
| W.O. Window #5 3'-0" x 5'-1" Stair Window |  | DH16 | Change from original spec F16 | SL16 | | | |
| | |  | OR |  | OR |  | NOT APPLICABLE |
| W.O. Window #6 3'-0" x 6'-1 1/2" Stair Window |  | DH24 | Change from original spec F24 | | | | |
| | |  | OR |  | | NOT APPLICABLE | |
| W.O. Window #7 3'-6 1/2" x 3'-2" Kitchen Window |  | SL12 | C12 | | AWN12 | | |
| | |  | OR |  | OR |  | |
| W.O. Window #8 4'-6" x 2'-1" Bathroom and Stair Top Landing |  | SL12 | C12 | | AWN12 | | |
| | |  | OR |  | OR |  | |

WINDOWS 5 - 8

| ROUGH OPENING W X H | ORIGINAL 1941 – 1943 WINDOWS | REPLACEMENT WINDOW PACKAGES | | | |
|--------------------------------------|---------------------------------|-----------------------------|-----------|-----------------|-------------------|
| | | PACKAGE 1 | PACKAGE 2 | PACKAGE 3 | AWNING OPTIONS |
| Window Types | Custom Steel | Double Hung Single Hung | Casement | Sliding | |
| W.O. Window #9 4'-6" x 4'-0 1/2" | | DH24 | C24 | SL24 | NOT APPLICABLE |
| W.O. Window #10 4'-6" x 5'-1 1/2" | | DH24 | C24 | SL24 | NOT APPLICABLE |
| W.O. Window #11 4'-6" x 6'-1 1/2" | | DH36 | C36 | SL36 or F36 | NOT APPLICABLE |
| W.O. Window #12 6'-0" x 4'-0 1/2" | | DH32 | C32 | SL24 | NOT APPLICABLE |
| W.O. Window #13 6'-0" x 5'-1" | | DH32 | C32 | SL24 | NOT APPLICABLE |

WINDOWS 9 - 13

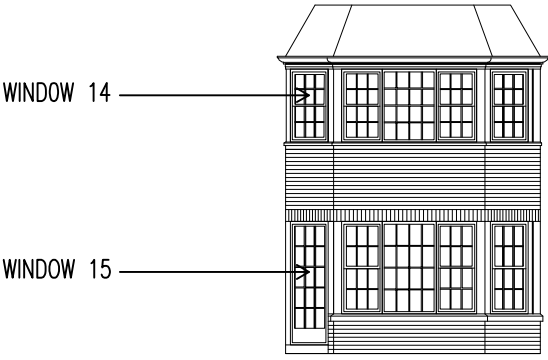
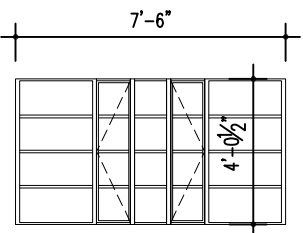
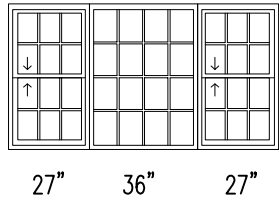
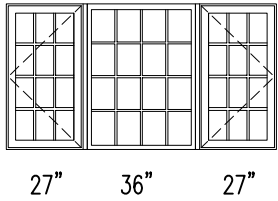
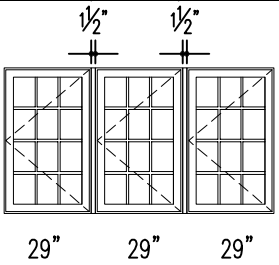
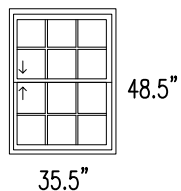
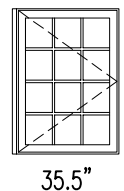
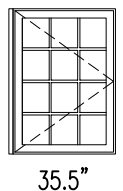
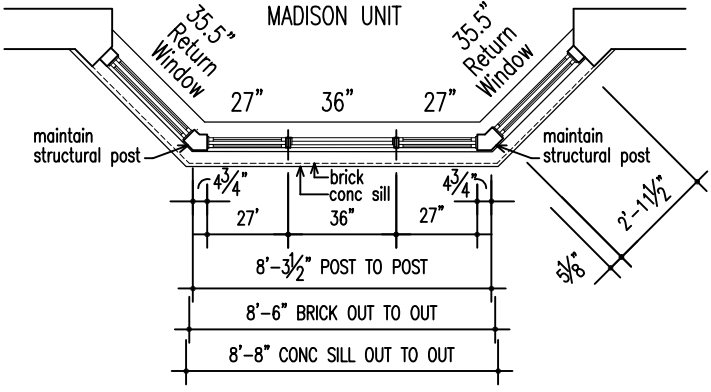
| | | | | |
|---|--|--|--|--|
| <p>SPECIAL REQUIREMENTS FOR BAY WINDOWS</p> | <p>THE SUPPORTS BETWEEN ON EITHER SIDE OF THE CENTER WINDOW ARE STRUCTURAL. A FULL TEAR-DOWN AND REPLACEMENT REQUIRE TEMPORARY SUPPORTS FOR STEEL LINTEL, BRICK, WINDOW, AND ROOF ABOVE.</p> |  | | |
| <p>ROUGH OPENING W X H</p> | <p>ORIGINAL 1941 – 1943 WINDOWS</p> | <p>REPLACEMENT WINDOW PACKAGES</p> | | |
| <p>Window Types</p> | <p>Custom Steel</p> | <p>PACKAGE 1</p> | <p>PACKAGE 2</p> | <p>PACKAGE 3</p> |
| <p>W.O. Window #14 7'-6" x 4'-0 1/2" Bay Window Madison Unit</p> |  | <p>Fixed Center Single or Double Hung Left + Right Sides</p> <p>DH12 F16 DH12</p>  | <p>Fixed Center Casement Left + Right Sides</p> <p>C12 F16 C12</p>  | <p>3 Casements Equal with spacers</p>  |
| <p>Return Windows W.O. Window #14R 7'-6" x 4'-0 1/2" Madison Unit</p> | <p>Not Available</p> | <p>#14DH12R</p> <p>Return Dbl Hung</p>  | <p>#14C12R</p> <p>Return Casement</p>  | <p>#14C12R</p> <p>Return Casement</p>  |
| <p>PLAN OF TYPICAL BAY WINDOW Madison Unit</p> | <p>Not Available</p> |  | | |

WINDOW 14

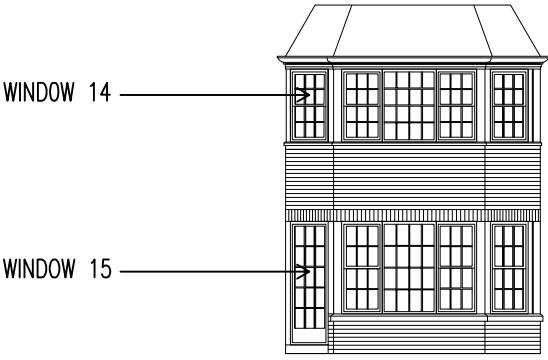
| | | |
|--|---|---|
| <p>SPECIAL REQUIREMENTS BAY WINDOW</p> | <p>THE SUPPORTS BETWEEN ON EITHER SIDE OF THE CENTER WINDOW ARE STRUCTURAL. A FULL TEAR-DOWN AND REPLACEMENT REQUIRE TEMPORARY SUPPORTS FOR STEEL LINTEL,</p> |  |
|--|---|---|

| | | | | |
|----------------------------|-------------------------------------|------------------------------------|------------------|------------------|
| <p>ROUGH OPENING W X H</p> | <p>ORIGINAL 1941 – 1943 WINDOWS</p> | <p>REPLACEMENT WINDOW PACKAGES</p> | | |
| | | <p>PACKAGE 1</p> | <p>PACKAGE 2</p> | <p>PACKAGE 3</p> |

| | | | | |
|---------------------|---------------------|--|---|---------------------------------------|
| <p>Window Types</p> | <p>Custom Steel</p> | <p>Fixed Center Single or Double Hung Left + Right Sides</p> | <p>Fixed Center Casement Left + Right Sides</p> | <p>3 Casements Equal with spacers</p> |
|---------------------|---------------------|--|---|---------------------------------------|

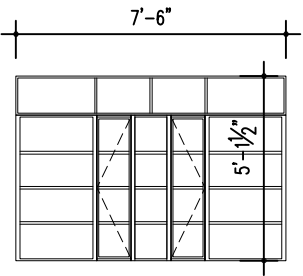
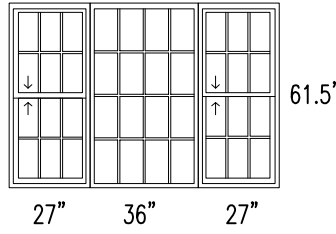
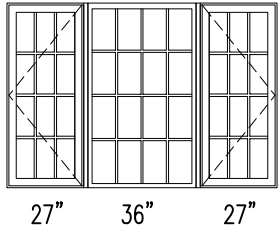
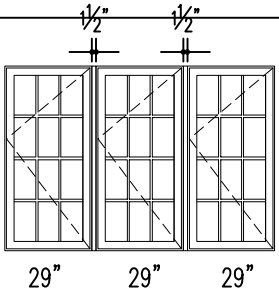
| | | | | |
|--|--|---|--|---|
| <p>W.O. Window #15 7'-6" x 5'-1 1/2" Bay Window Lincoln Unit</p> |  | <p>DH12 F16 DH12</p>  | <p>C12 F16 C12</p>  | <p>C12 C12 C12</p>  |
|--|--|---|--|---|

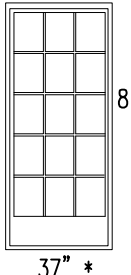
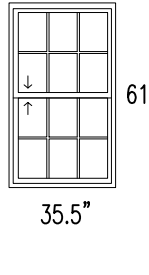
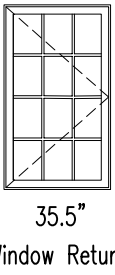
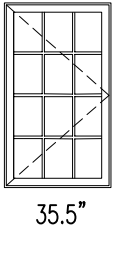
| | | | | | |
|---|----------------------|--|---|--|--|
| <p>Return Window & Return Door W.O. Door R Window #15R 7'-6" x 5'-1 1/2" Lincoln Unit</p> <p>* Custom Door 36" Width OK</p> | <p>Not Available</p> | <p>Door R</p>  <p>37" *</p> | <p>#15DH12R</p> <p>Return Dbl Hung</p>  <p>61.5" 35.5"</p> | <p>#15CR</p> <p>Return Casement</p>  <p>35.5" Window Return</p> | <p>#15CR</p> <p>Return Casement</p>  <p>35.5"</p> |
|---|----------------------|--|---|--|--|

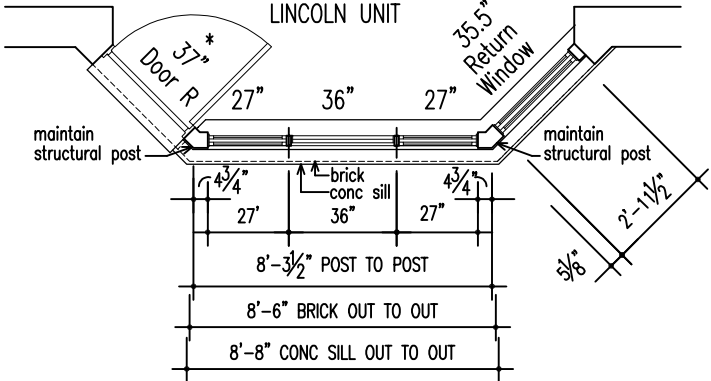
| | | |
|--|----------------------|--|
| <p>PLAN OF TYPICAL BAY WINDOW Lincoln Unit</p> | <p>Not Available</p> |  |
|--|----------------------|--|

WINDOW 15